

GALVASHIELD® XP2 ANODE PROPERTIES	
MINIMUM WEIGHT OF ZINC CORE	100 g
OVERALL LENGTH OF TIE WIRES	350 mm
NOMINAL DIMENSIONS OF ANODE	80 mm x 65 mm x 30 mm
ANODE TYPE / CLASS	1A / C
ALKALI ACTIVATED CORROSION CONTROL	

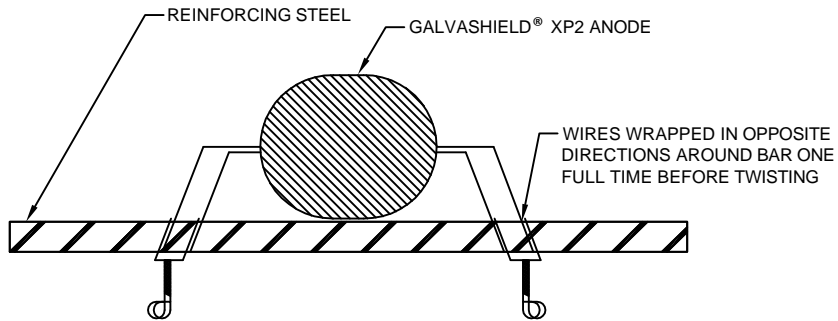

1. REMOVE DAMAGED CONCRETE AS PER STANDARD REPAIR METHODS.
2. REPLACE/CLEAN ANY CORRODED REINFORCING STEEL.
3. ENSURE EXPOSED REINFORCING STEEL IS SECURELY FASTENED WITH TIE WIRE TO PROVIDE GOOD ELECTRICAL CONTINUITY.
4. ATTACH GALVASHIELD® XP2 ANODES TO CLEAN REINFORCING STEEL AT AN EVEN SPACING WITHIN PATCH AREA, OR AS OUTLINED IN PROJECT SPECIFICATIONS (MAX 750mm).
5. GALVASHIELD® XP2 ANODES ARE INSTALLED ALONG THE PERIMETER OF THE REPAIR AREA WHEN ALL CHLORIDE CONTAMINATED CONCRETE HAS BEEN REMOVED. IF ANY CHLORIDE CONTAMINATED CONCRETE REMAINS WITHIN THE REPAIR AREA AND IS IN CONTACT WITH ANY LAYER OF REINFORCING STEEL THEN IT MAY BE NECESSARY TO PLACE GALVASHIELD® XP2 ANODES IN A GRID PATTERN WITHIN THE INTERIOR OF THE REPAIR AREA.
6. TEST ELECTRICAL CONTINUITY OF THE REINFORCING STEEL BEFORE INSTALLATION AND REPAIR AS NECESSARY. TEST ELECTRICAL CONTINUITY OF ANODE CONNECTION TO REINFORCING STEEL AFTER INSTALLATION. A DC VOLTAGE MEASUREMENT OF 1mV CONFIRMS GOOD CONTINUITY.
7. POUR BACK REPAIR AREA WITH COMPATIBLE REPAIR MATERIAL AS PER PROJECT SPECIFICATIONS.



PLAN OF TYPICAL INSTALLATION TO SIDE OF REBAR

N.T.S.

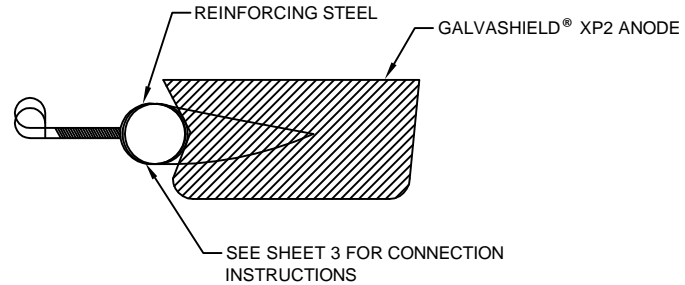

SECTION OF TYPICAL CONNECTION TO SIDE OF REBAR

N.T.S.

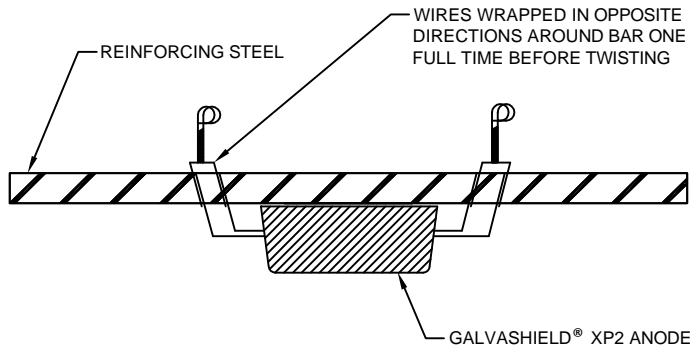

ELEVATION OF TYPICAL INSTALLATION BELOW REBAR

N.T.S.

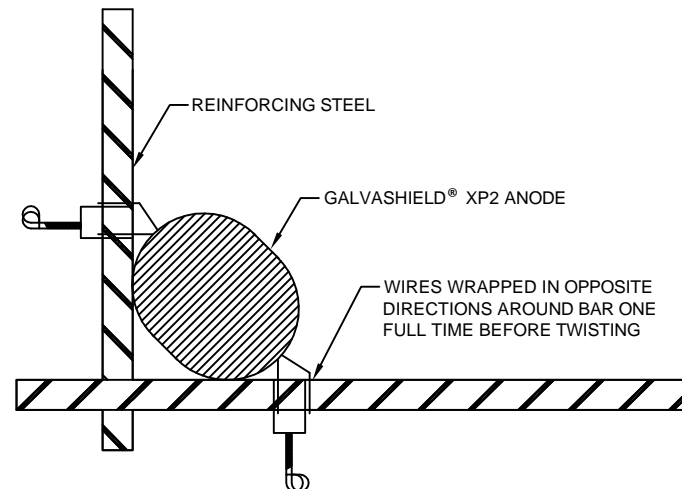

PLAN OF TYPICAL INSTALLATION AT REBAR INTERSECTION

N.T.S.

**GALVASHIELD® XP2
EMBEDDED
GALVANIC ANODES**

**TYPICAL INSTALLATION
DETAILS**

BY: JWH DATE: Nov 20-2012

SHEET: 1 OF 3

XP2 CONNECTION.DWG

1. FOR REPAIR MATERIALS WITH A HIGH RESISTIVITY (GREATER THAN 15 000 Ohm-cm) A LOW-RESISTIVITY MORTAR POCKET MUST BE INSTALLED.

2. INSTALL GALVASHIELD® XP2 ANODE AS NORMAL.

3. MORTAR POCKET MUST BE MADE USING EITHER GALVASHIELD® EMBEDDING MORTAR OR ANY REPAIR MATERIAL WITH RESISTIVITY LESS THAN 15,000 Ohm-cm.

4. MORTAR POCKET WILL COMPLETELY FILL THE SPACE BETWEEN THE ANODE AND CONCRETE OVER A MINIMUM AREA OF 100mm IN DIAMETER.

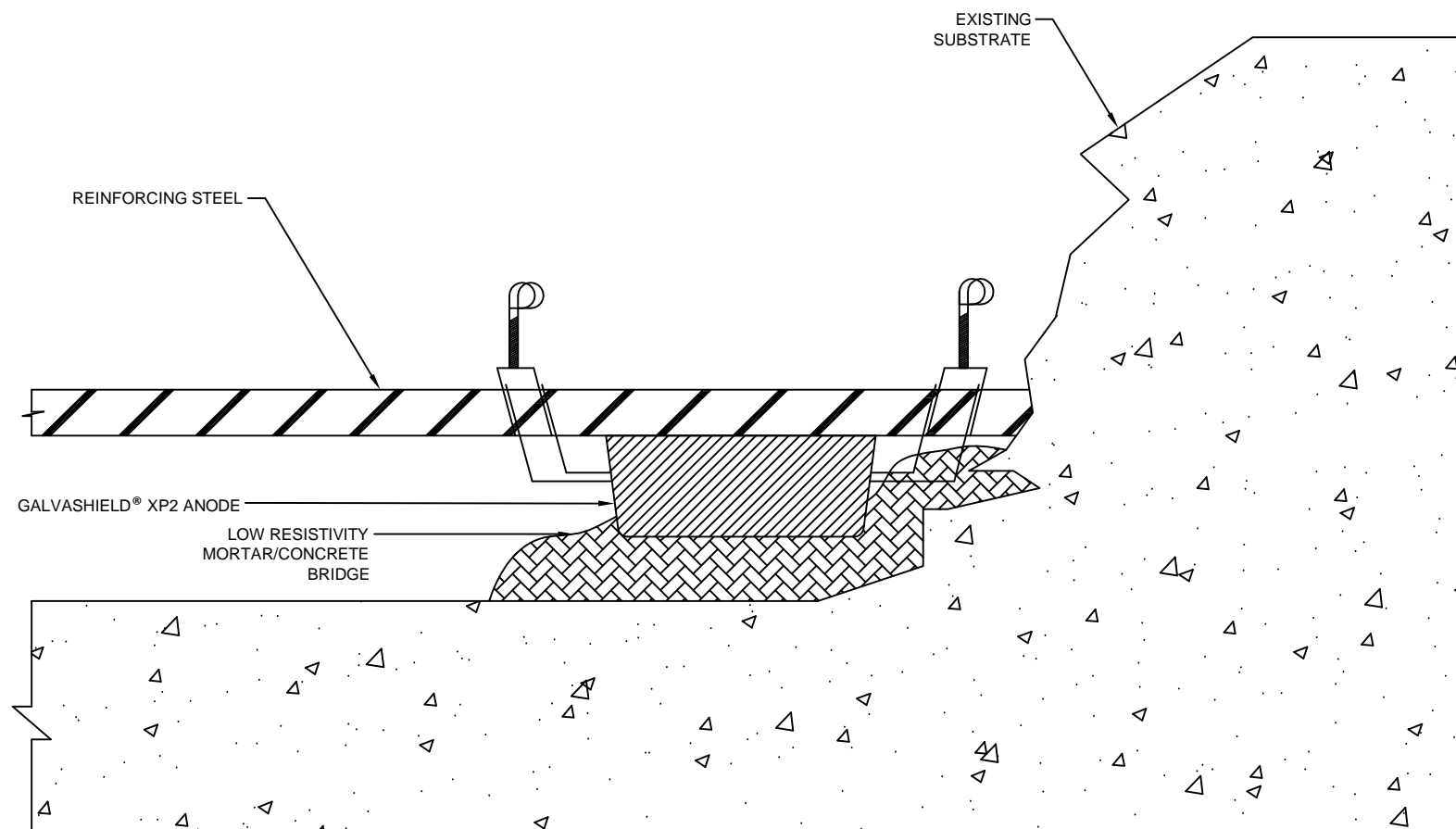

CONDUCTIVE MORTAR BRIDGE FOR USE WITH HIGH RESISTIVITY REPAIR MORTARS

N.T.S.

**GALVASHIELD® XP2
EMBEDDED
GALVANIC ANODES**

**TYPICAL INSTALLATION
DETAIL FOR HIGH
RESISTIVITY REPAIR
MATERIALS**

BY: JWH DATE: Nov 20-2012

SHEET: 2 OF 3

XP2 CONNECTION.DWG

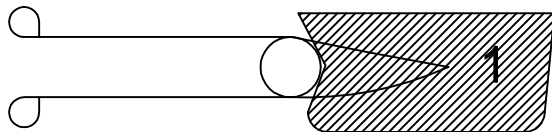

1: PLACE ANODE SNUGLY AGAINST FACE OF REINFORCING STEEL WITH ONE (1) WIRE ON EITHER SIDE OF REINFORCING STEEL

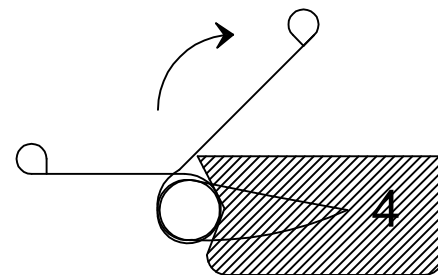

4 & 5: BEND SECOND WIRE COMPLETELY AROUND REINFORCING STEEL IN THE OPPOSITE DIRECTION

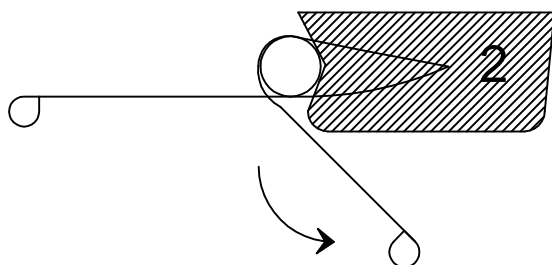

2 & 3: BEND ONE WIRE COMPLETELY AROUND REINFORCING STEEL

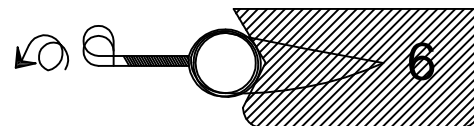
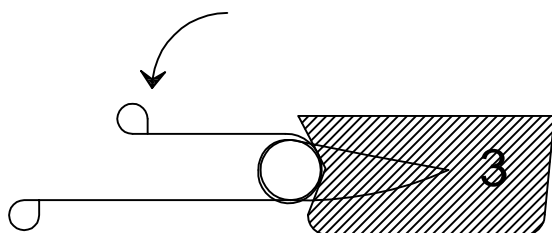
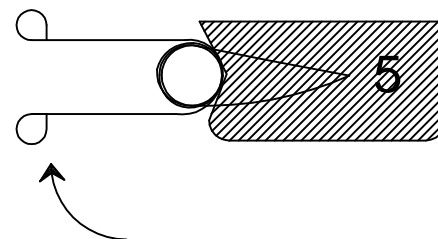

6: TWIST WIRES TOGETHER TIGHTLY TO COMPLETE THE CONNECTION, TAKE CARE NOT TO BREAK THE WIRES

**GALVASHIELD® XP2
EMBEDDED
GALVANIC ANODES**

**STEP BY STEP TIE WIRE
WRAP INSTALLATION
DETAIL**

BY: JWH DATE: Nov 20-2012

SHEET: 3 OF 3

XP2 CONNECTION.DWG